

# Univers Revers™ Modular Glenoid System

Surgical Technique

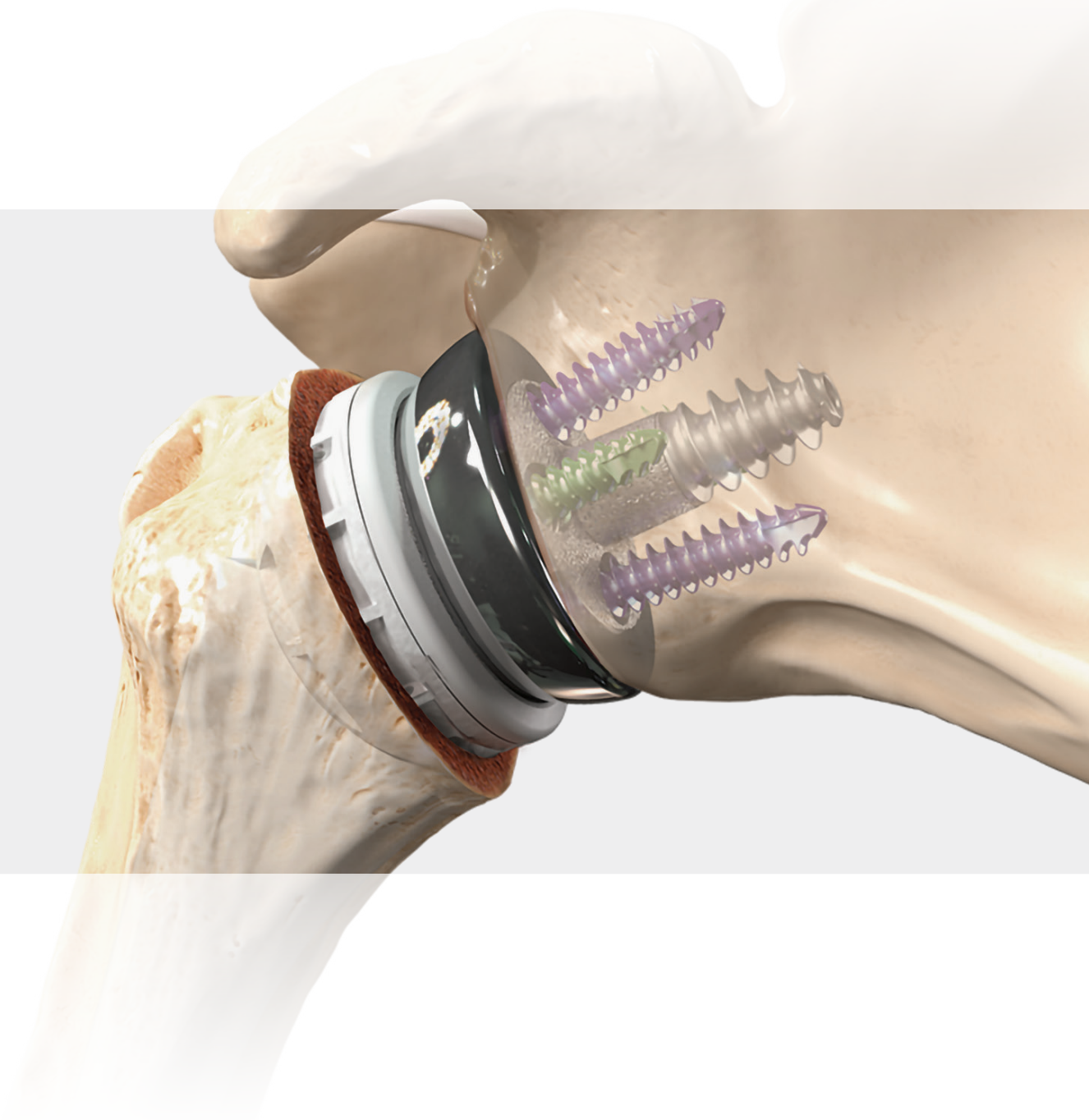

**Arthrex®** 



---

# Univers Revers™ Modular Glenoid System

## Introduction

---

The Univers Revers Modular Glenoid System, a complementary addition to the Univers Revers total shoulder system, builds upon the design concept of providing options that fulfill our mission of Helping Surgeons Treat Their Patients Better®. By providing a multitude of component choices, Arthrex is helping surgeons tailor procedures to individual patient needs.

The Modular Glenoid System is designed to work only with Univers Revers humeral components and is not cleared by the FDA for use with any other reverse shoulder arthroplasty system.



## Baseplates

---

- 24 mm and 28 mm diameters
- +0 mm, +2 mm, +4 mm lateral offset options
- BioSync® matrix with interconnected porosity for ingrowth<sup>1</sup>
- 4 peripheral screw holes accommodate 5.5 mm locking or 4.5 mm nonlocking screws



## Central Fixation

---

- Hybrid central screw for compression and ingrowth
- Central post for press-fit and ingrowth
- Numerous lengths to address various glenoid vault depths (15 mm to 35 mm)
- BioSync matrix with interconnected porosity for ingrowth<sup>1</sup>



## Glenospheres

---

- 33 mm, 36 mm, 39 mm, 42 mm, and 45 mm diameters
- +0 mm, +4 mm lateralized, and +2.5 mm eccentric offset options
- Titanium option available for patients with cobalt alloy sensitivity





## Glenoid Exposure

---

For patient positioning, surgical exposure, and humeral preparation steps, please refer to these sections within the Unvers Revers™ Shoulder System Humeral Preparation Surgical Technique (LT1-000175-en-US).

### Preoperative Planning

Preoperative planning may have the greatest impact on the surgical outcome, especially if it is overlooked. Good-quality shoulder radiographs should include a true A/P, axillary lateral, and supraspinatus outlet view. The technician should use a reproducible process that generates images with consistent and predictable magnification for templating. The Unvers Revers total shoulder system includes a set of templating transparencies for glenoid and humeral component sizing. Additional radiographic studies such as CT and MRI to evaluate glenoid geometry and soft-tissue quality, respectively, complement a thorough diagnostic workup. With a CT study, the Arthrex Virtual Implant Positioning™ (VIP™) system can be used to accurately plan and execute glenoid component implantation.

### Glenoid Exposure

Begin glenoid exposure with a complete anterior/inferior capsulotomy as described in the Unvers Revers Shoulder System Humeral Preparation Surgical Technique (LT1-000175-en-US). This not only aids visualization of the entire glenoid, but improves motion postoperatively. Following the initial capsular release to the 6 o'clock position, further posterior release may be necessary for complete glenoid visualization. Once the axillary nerve is identified, capsular release may continue unimpeded until complete glenoid visualization is accomplished. If the glenoid remains poorly visualized after the release of the anterior, inferior, and posterior capsules, additional steps may be necessary to achieve a direct approach to the glenoid. For example, verify humeral osteotomy because insufficient humeral head resection can result in poor glenoid visualization. Full release of the deltopectoral interval should be confirmed. Additional release of the pectoralis major tendon can be performed with tendon repair during closure. Up to 1.5 cm of the tendon can be released safely and without consequence to increase visualization.

On the deltoid side, the anterior attachment of the deltoid on the deltoid tubercle of the humerus can also be partially released. Once a direct view of the glenoid is possible, place a glenoid neck retractor along the anterior glenoid neck, as medial as possible. To help with glenoid exposure, it is recommended to place a glenoid retractor in the posterior inferior quadrant, (5 o'clock position in a left shoulder and 7 o'clock position in a right shoulder) to retract the humerus posteriorly and inferiorly. This will help with the orientation of the glenoid, especially in cases where significant posterior erosion has occurred. In any case, the important principle is to have direct visualization of the face of the glenoid. Any malposition of the glenoid component can lead to early failure.

Following exposure of the native glenoid, begin preparing the glenoid per the Unvers Revers™ Modular Glenoid System Surgical Technique (LT1-00112-EN).

## Glenoid Surface Preparation

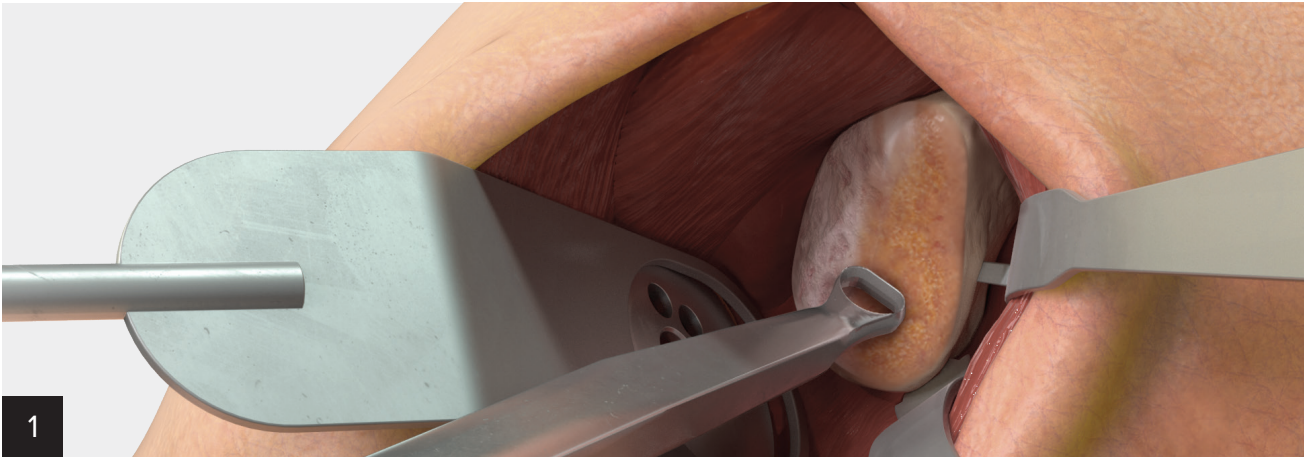

Prepare the glenoid for reaming by removing the surface cartilage using the glenoid scrapette. Either end of the glenoid scrapette instrument, the ring curette, or the Cobb elevator can be used for this purpose.

## Glenoid Sizing and Guidewire Placement

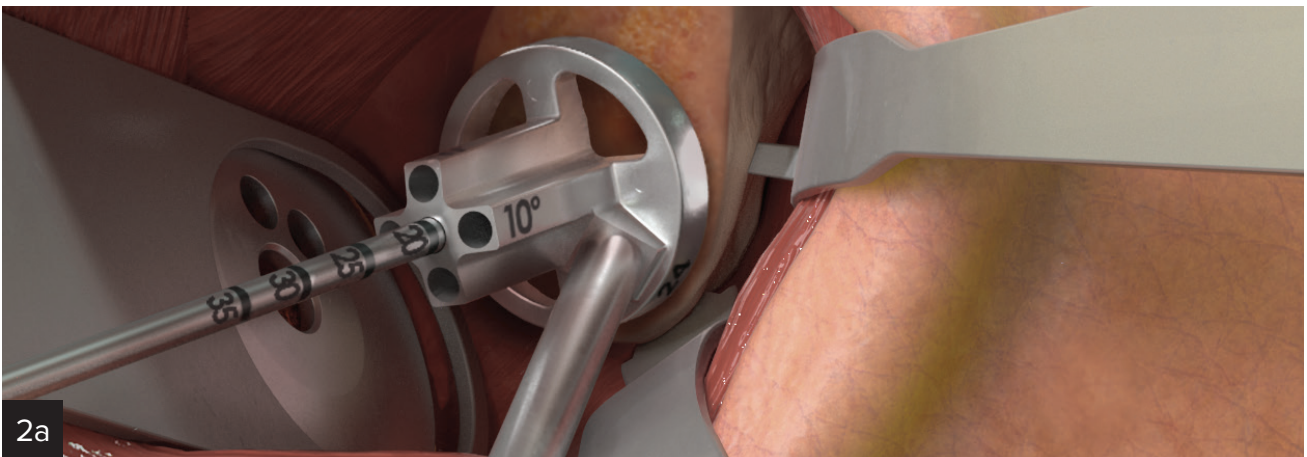

Select the appropriately sized glenoid sizer/pin guide (24 mm or 28 mm) based on the diameter of the desired glenoid baseplate. Place the pin guide onto the glenoid face and insert the 2.8 mm guidewire into the selected hole.

**Note: There are 5 holes within the pin guide. The 4 peripheral holes all orient the guidewire 10° divergent from neutral. The central hole provides a neutral guidewire trajectory.**

The 2.8 mm guidewire has markings to indicate placement depth within the glenoid vault. Drive the guidewire to the desired depth, taking note of the laser line just outside of the pin guide. This measurement will determine the size of the central post or central screw that should be used. Remove the pin guide, leaving the guidewire in place.

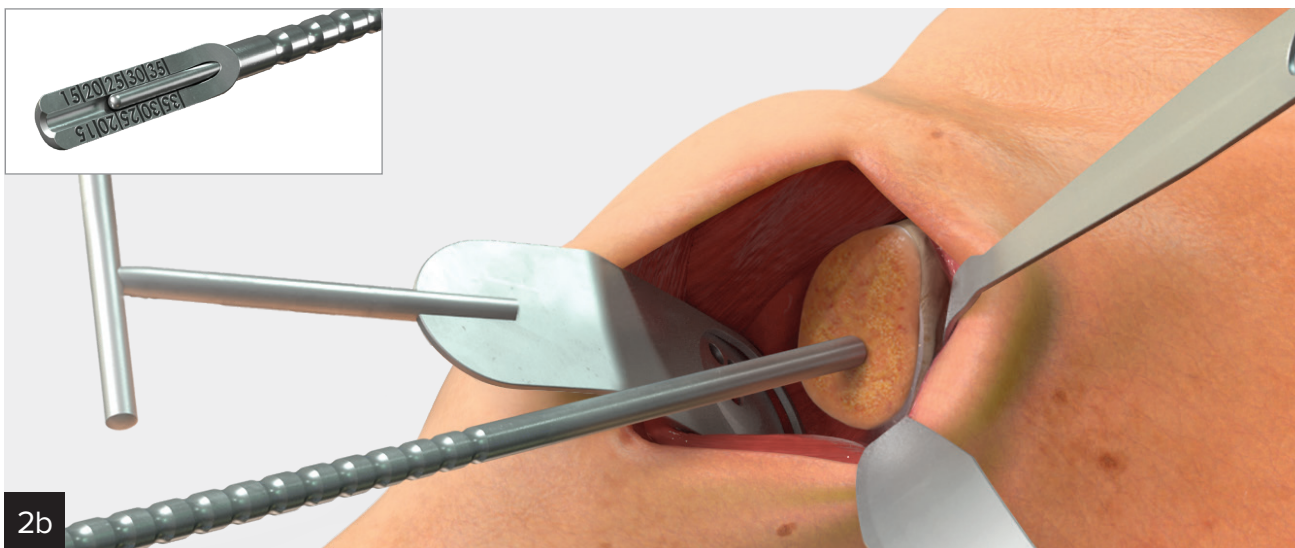

If preferred, the pin depth within the glenoid vault may be measured by sliding the guidewire depth gauge over the 2.8 mm guidewire. The depth markings on this guide correspond to the lengths of the central posts or screws that may be chosen.

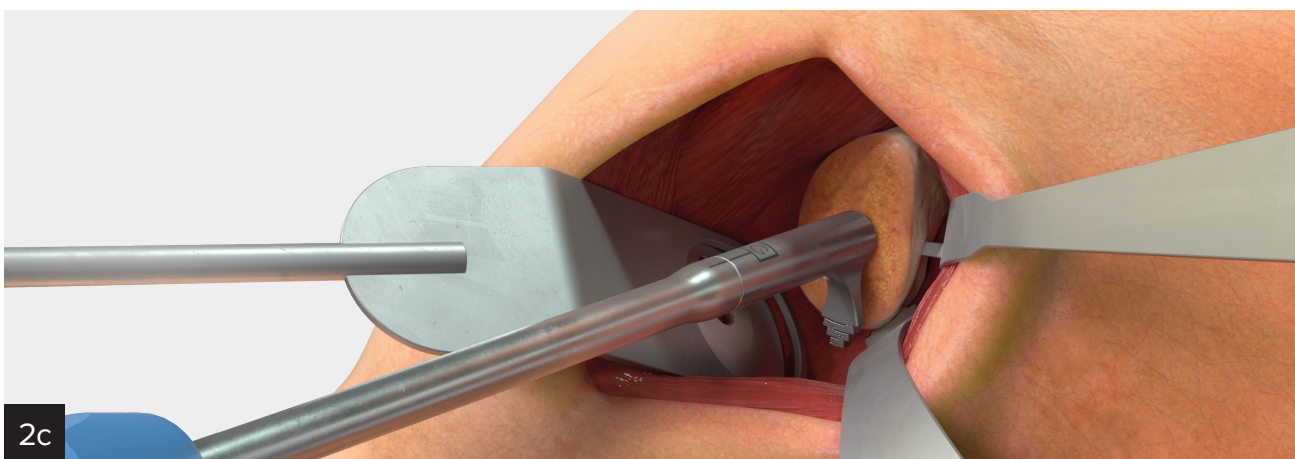

To assess glenosphere sizing and positioning relative to guidewire placement, the glenosphere sizing guide can be introduced over the guidewire. The barbs on the sides of the guide correspond to each of the glenosphere diameters available within the system.



## Primary Glenoid Reaming

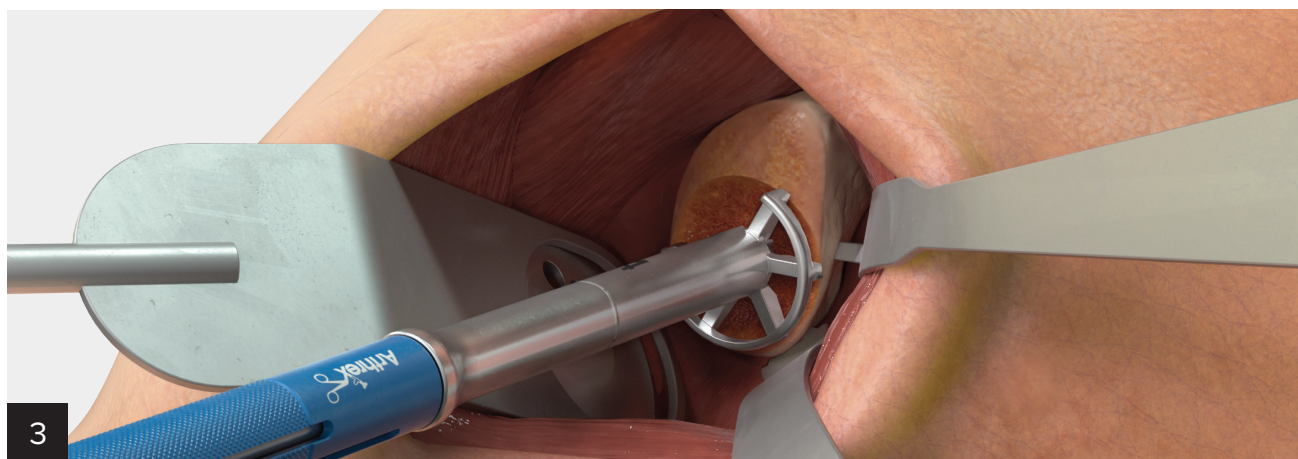

**Preparation for Backside of Baseplate:** Select the glenoid reamer corresponding to the desired implant size (24 mm or 28 mm). Connect the glenoid reamer to the modular reamer shaft. Insert the reamer assembly over the guidewire and advance it to achieve congruency between the reamer and glenoid face. This reamer does not have a positive stop. Remove the reamer assembly, leaving the guidewire in place.

**Note:** Begin reaming prior to placing the reamer on the glenoid face. Starting the reamer while seated increases the risk of glenoid fracture.

## Peripheral Glenoid Reaming

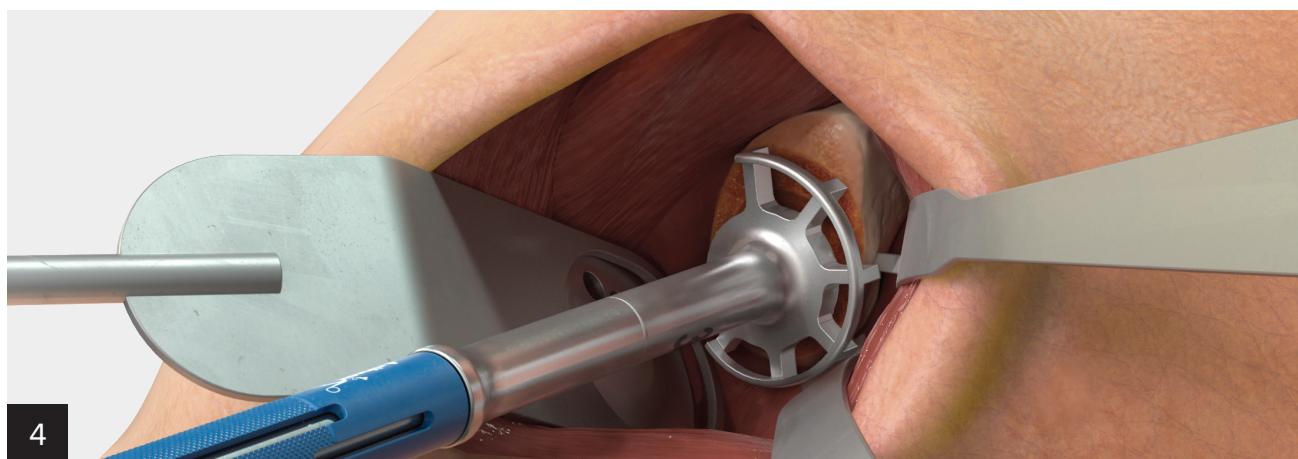

**Preparing Underside of Glenosphere:** Select the peripheral glenoid reamer corresponding to the desired glenosphere size and attach it to the modular reamer shaft. Insert the reamer assembly over the guidewire. The reamer face has a positive stop and will prevent overmedialization of the prepared bone.

**Note:** If an inferior offset glenosphere is desired, perform additional inferior reaming manually as described in Step 5.

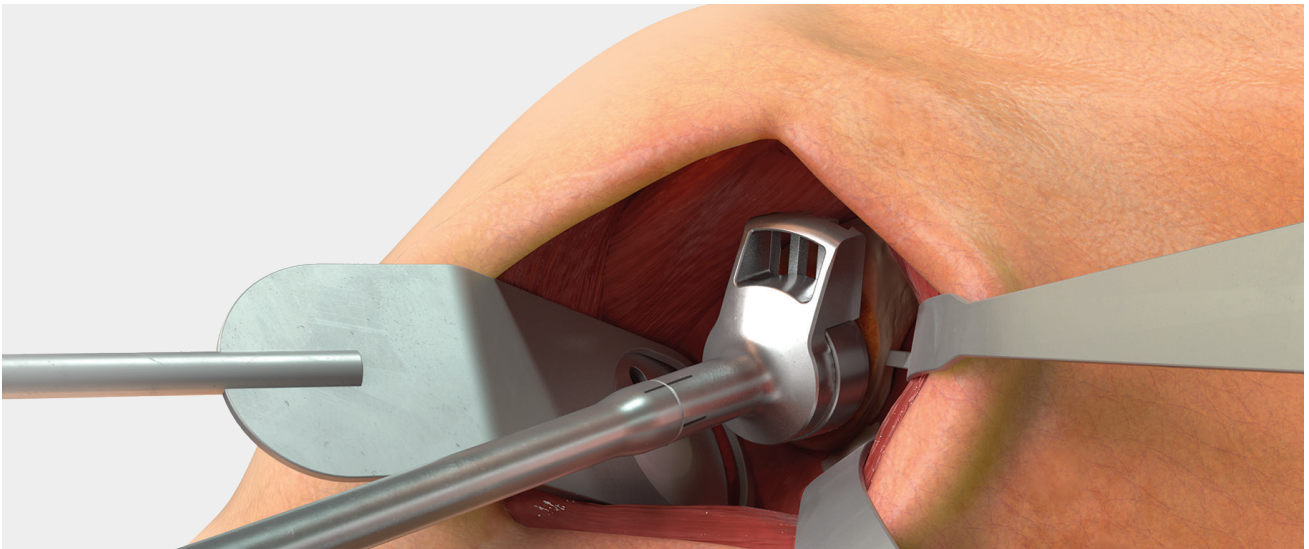

**Optional Step 4:** Once the baseplate has been implanted, the over-the-baseplate reamer may be used to ensure adequate peripheral reaming has been achieved. If desired, this is a secondary peripheral reaming step and should not replace Step 4. To perform this step, place the over-the-baseplate peripheral reamer onto the manual driver. Advance the reamer assembly onto the baseplate face, so that the nub from the peripheral reamer seats within the central threaded hole of the baseplate.

Using a clockwise/counterclockwise motion, ream the peripheral tissue as desired (see illustration). The reamer face has a positive stop and will prevent the reamer from overmedializing the bone beyond what was prepared in Step 3.

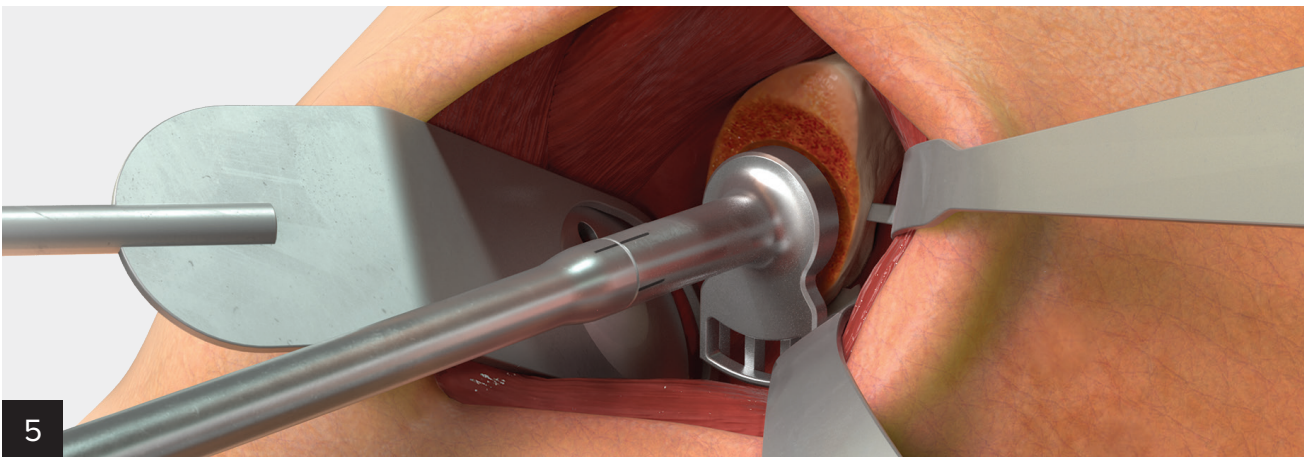

**For Inferior Offset Glenospheres:** If an inferior/eccentric glenosphere is selected, additional reaming must be performed to provide clearance between the glenoid bone and the underside of the glenosphere. To do so, attach the inferior glenoid reamer to the manual driver.

Insert the reamer assembly over the guidewire. Using a clockwise/counterclockwise motion, ream the inferior bone as desired (see illustration). The reamer face has a positive stop and will prevent the reamer from overmedializing the bone beyond what was prepared in Step 3.



## Central Screw/Post Preparation

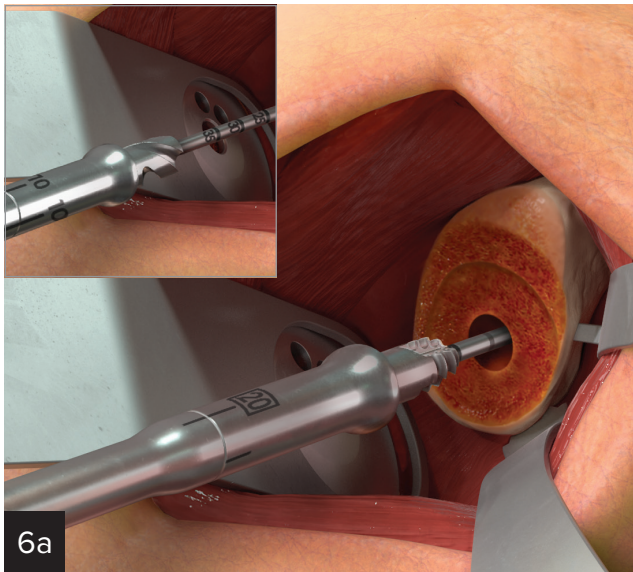

Modular Central Screw Preparation

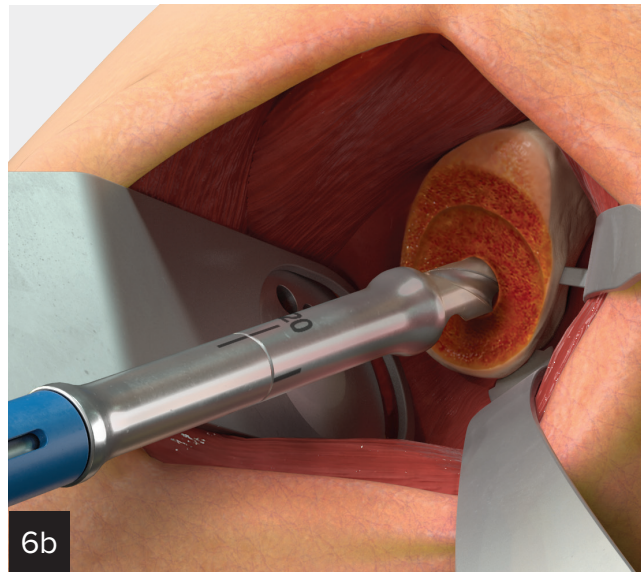

Modular Post Preparation

The Modular Glenoid System provides 3 options for central fixation: a baseplate with integrated central screw/post (monoblock), a modular central ingrowth post, or a modular central screw. The preparation for each varies slightly and is detailed below.

### ■ Modular Central Screw Preparation:

Attach the 10 mm drill to the modular reamer shaft. Place the drill assembly over the guidewire and advance until the collar of the drill is flush with the glenoid face. This prepares the bone for the BioSync® collar on the modular central screw. Next, attach the tap corresponding to the depth marking noted from the initial guidewire placement (20 mm, 25 mm, 30 mm, or 35 mm) onto the manual driver. Insert the tap assembly over the guidewire and advance until the collar of the tap is flush with the glenoid face. After removing the tap assembly, the guidewire may be removed or left in place.

### ■ Monoblock Central Screw Preparation:

Attach the 15 mm tap to the manual driver. Insert the tap assembly over the guidewire and advance until the tap collar is flush with the glenoid face. After removing the tap assembly, the guidewire may be removed or left in place.

### ■ Modular Central Post Preparation:

Select the drill size corresponding to the depth marking noted from the initial guidewire placement (20 mm, 25 mm, 30 mm, or 35 mm). Attach the selected drill to the modular reamer shaft. Place the drill assembly over the guidewire and advance on power until the collar of the drill is flush with the glenoid face. After removing the drill assembly, the guidewire may be removed or left in place.

### ■ Monoblock Central Post Preparation:

Attach the 15 mm drill to the modular reamer shaft. Insert the drill assembly over the guidewire and advance on power until the collar of the drill is flush with the glenoid face. After removing the drill assembly, the guidewire may be removed or left in place.

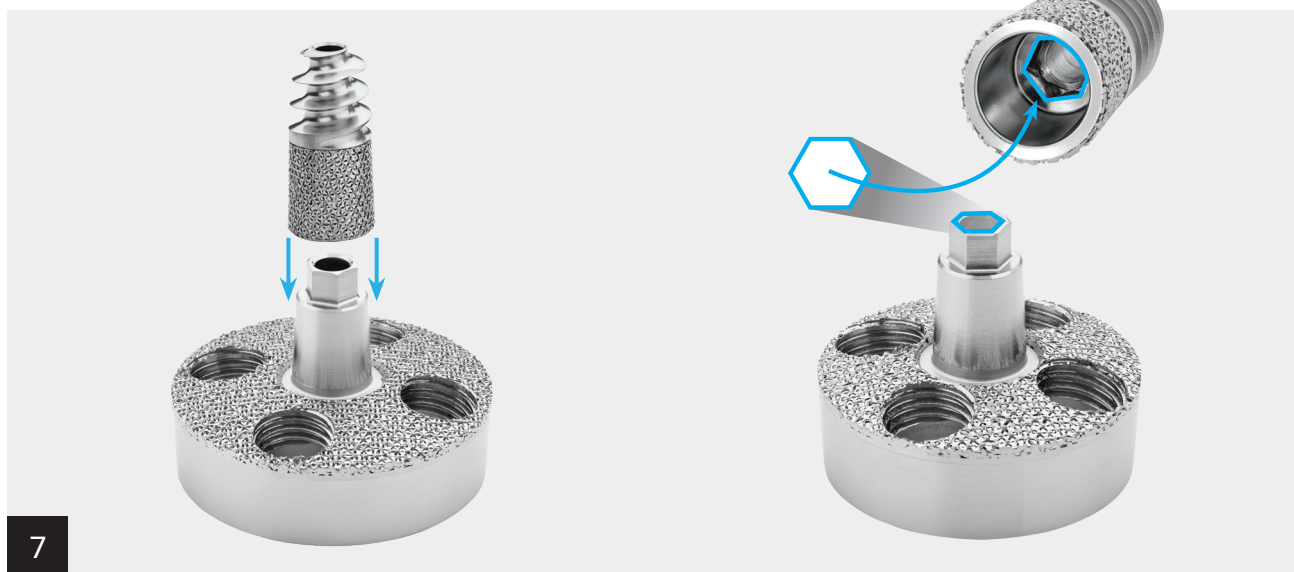

7

Combine the modular central screw or post with the modular baseplate component. These components mate via a taper connection.

**Note: If opting to use a monoblock component, proceed to Step 8: Baseplate Implantation.**

There is a hex tip that must be aligned between the components in order for the taper to engage (see illustration). Rotate the components until the hex features align, resulting in a tactile coupling. Place the joined components within the taper assembly stand so that the central post/screw is facing up.

**Note: Use the taper press to ensure proper taper connection between components.**

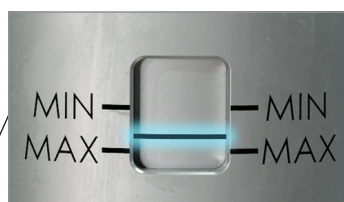
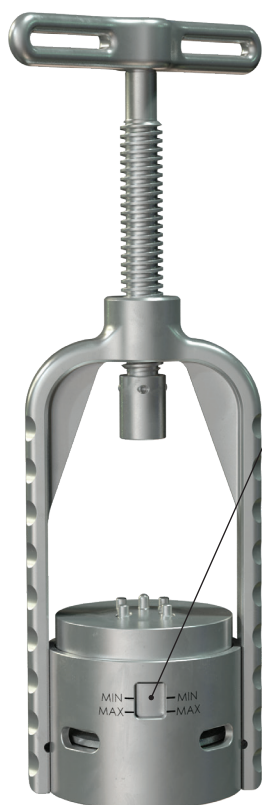

Turn the taper assembly handle, tightening until the taper assembly stand's indicator line falls between the laser lines in the taper assembly window. This measure indicates that the components have been compressed adequately for seating the taper connection.

Unscrew the taper assembly stand and remove the implant.

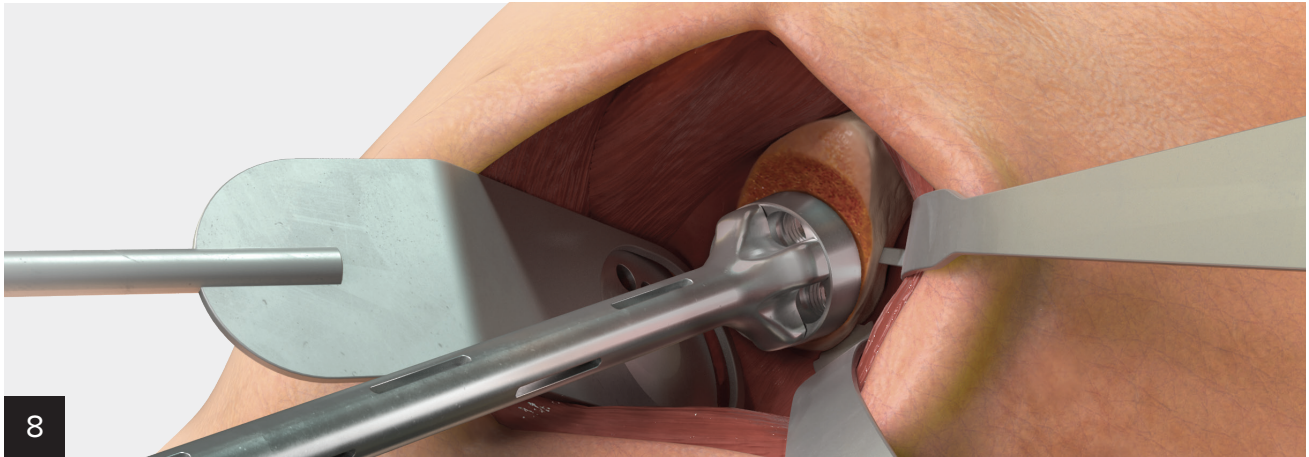

Two baseplate inserters are available, depending on surgeon preference. The threaded, noncannulated version should be used to insert the baseplate if the guidewire has been removed. The cannulated version should be used to insert the baseplate over a guidewire.

### **8a Implantation Without Guidewire:**

Place the baseplate component(s) onto the threaded inserter/impactor. Take care to align the 4 metal nubs on the threaded inserter/impactor face with the 4 small holes on the periphery of the baseplate face. Thread the central rod from the threaded inserter/impactor into the baseplate so that the faces of the baseplate and inserter/impactor are flush.

#### ■ **For Central Screw:**

Align the baseplate component to the prepared central hole and rotate clockwise, advancing the baseplate medially until it is flush with the prepared glenoid face and desired compression is achieved. Care should be taken to orient the peripheral screw holes in the desired location. Unthread the inserter/impactor from the baseplate and set aside.

#### ■ **For Central Post:**

Advance the tip of the central post until it is slightly engaged in the prepared central hole within the glenoid face. Rotate the baseplate until optimized peripheral screw location is achieved. Lightly impact the threaded inserter/impactor with a mallet until the baseplate is fully seated on the glenoid face. Unthread the inserter/impactor from the baseplate and set aside.

### **8b Implantation With Guidewire:**

Place the baseplate component(s) over the guidewire and advance until it contacts the glenoid surface. Insert the cannulated baseplate inserter/impactor over the guidewire and advance, taking care to align the 4 metal nubs on the inserter/impactor face with the 4 small holes within the baseplate face.

#### ■ **For Central Screw:**

Align the baseplate component to the prepared central hole and rotate clockwise, advancing the baseplate medially until it is flush with the prepared glenoid face and desired compression is achieved. Care should be taken to orient the peripheral screw holes in the desired location. Remove the inserter/impactor from the baseplate and set aside. Remove the guidewire.

#### ■ **For Central Post:**

Advance the tip of the central post until it is slightly engaged in the prepared central hole within the glenoid face. Rotate the baseplate until optimized peripheral screw location is achieved. Lightly impact the threaded inserter/impactor with a mallet until the baseplate is fully seated on the glenoid face. Remove the inserter/impactor from the baseplate and set aside. Remove the guidewire.



## Peripheral Screw Preparation

The peripheral screw holes in the system's baseplates accept locking or nonlocking screws.

**Note:** It is recommended that a minimum of 2 peripheral screws be used in the baseplate. If bone stock is available, superior and inferior screw locations are preferable to maximize implant security.

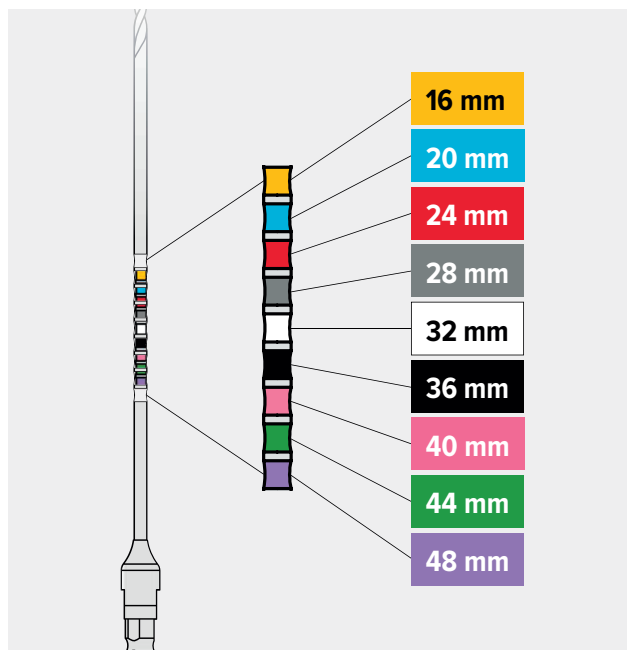
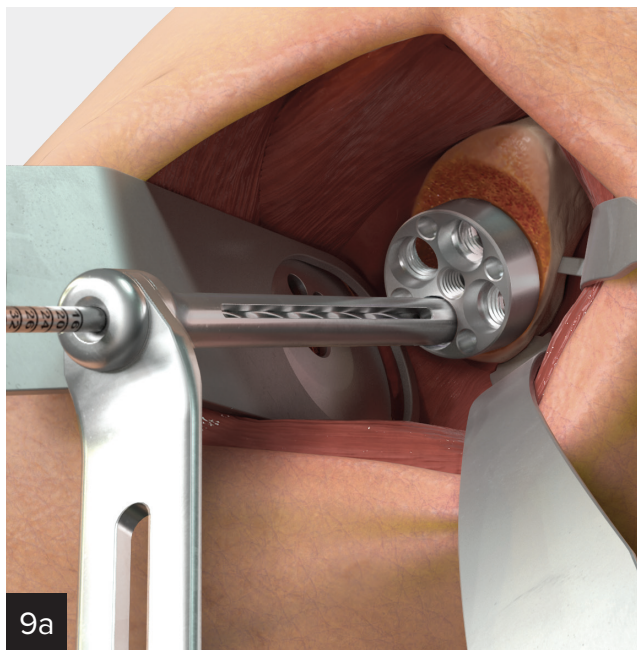

**Nonlocking 4.5 mm Screws:** Place the nonlocking peripheral screw drill guide in any hole of the baseplate and orient to the desired screw trajectory. Advance the 3 mm drill through the guide, taking note of the depth marks on the drill shaft, which indicate screw length. Alternatively, a depth gauge may be used to determine the peripheral screw length. Repeat the process to prepare for each additional nonlocking screw.

If using the single-use, sterile drill (AR-9628S), please refer to the peripheral screw depth chart above.

**Optional Step: Speed Guide (for nonlateralized baseplates only)** A speed guide for nonlocking screws may be attached to the face of the baseplate for rapid screw preparation in a fixed, neutral orientation for nonlocking screws. It should not be used with locking screws, as they lock into the baseplate at a divergent angle.

- Seat the speed guide onto the baseplate face and attach using the interior threaded screw and the 3 mm hex driver. Drill through the speed guide holes, noting the length of each screw via the depth markings on the drill shaft. Remove the speed guide from the baseplate using 3 mm hex driver.

Attach the 3 mm hex driver to the quick-connect coupling on the ratcheting handle. Ensure that the ratcheting handle is set to "Forward" or "Locked." Place the tip of the hex driver into the selected screw head and insert into the appropriate screw hole within the baseplate. Advance the screw until fully seated.

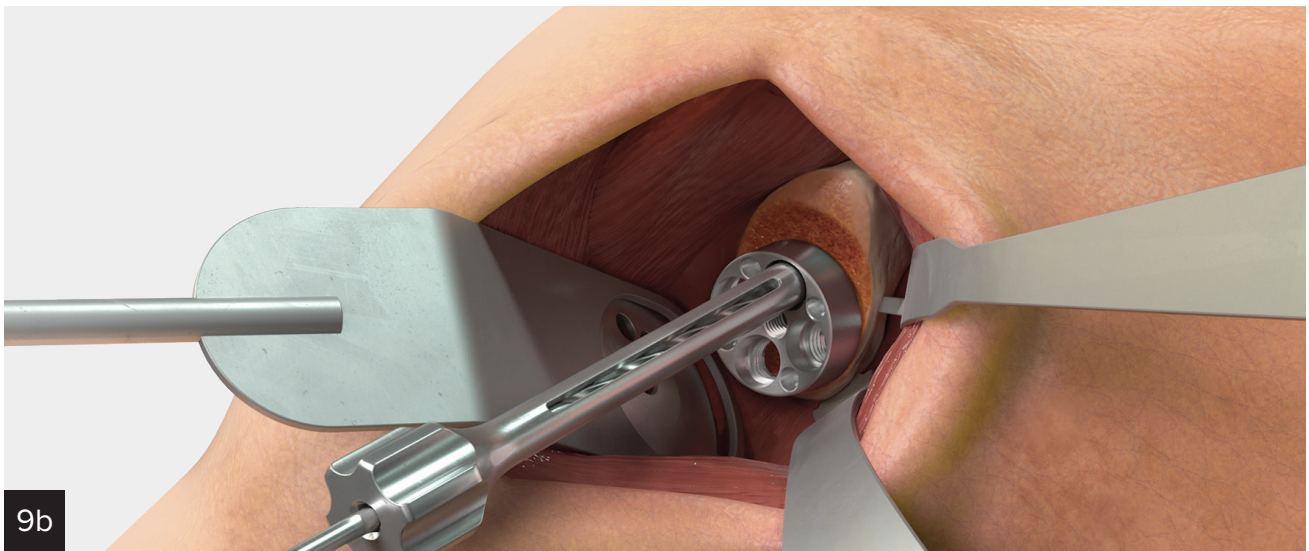

**Locking 5.5 mm Screws:** Thread the locking peripheral screw drill guide into any screw hole in the baseplate. Advance the 3 mm drill through the guide, taking note of the depth marks on the drill shaft, which indicate screw length. Alternatively, a depth gauge may be used to assess the peripheral screw length. Repeat the process to prepare for each additional locking screw.

Attach the 3 mm hex driver to the quick-connect coupling on the ratcheting handle. Ensure that the ratcheting handle is set to “Forward” or “Locked.” Place the tip of the hex driver into the selected screw head and insert into the appropriate screw hole in the baseplate. Advance the screw until fully seated.

**Note:** All screw heads should be slightly recessed relative to the baseplate surface to ensure sufficient clearance for glenosphere seating.

**If using the single-use, sterile drill (AR-9628S), please refer to the peripheral screw depth chart on the previous page.**

## Screw Angulation



	Nonlocking	Locking
24	20°	10°
28	20°	10°
24+2	16°	8°
28+2	20°	10°
24+4	12°	6°
28+4	18°	9°

**Note:** The screw angulation of nonlocking (variable-angle) and locking screws changes slightly based on the chosen baseplate. For specific angles, reference the chart above.

## Glenosphere Trialing and Insertion

Thread the glenosphere trial onto the tip of the glenosphere inserter handle. Place the trial glenosphere onto the baseplate, pressing lightly to seat the taper. Remove the glenosphere inserter handle. To separate the glenosphere trial from the baseplate, thread the glenosphere inserter handle onto the trial and pull gently in an axial fashion to remove it.

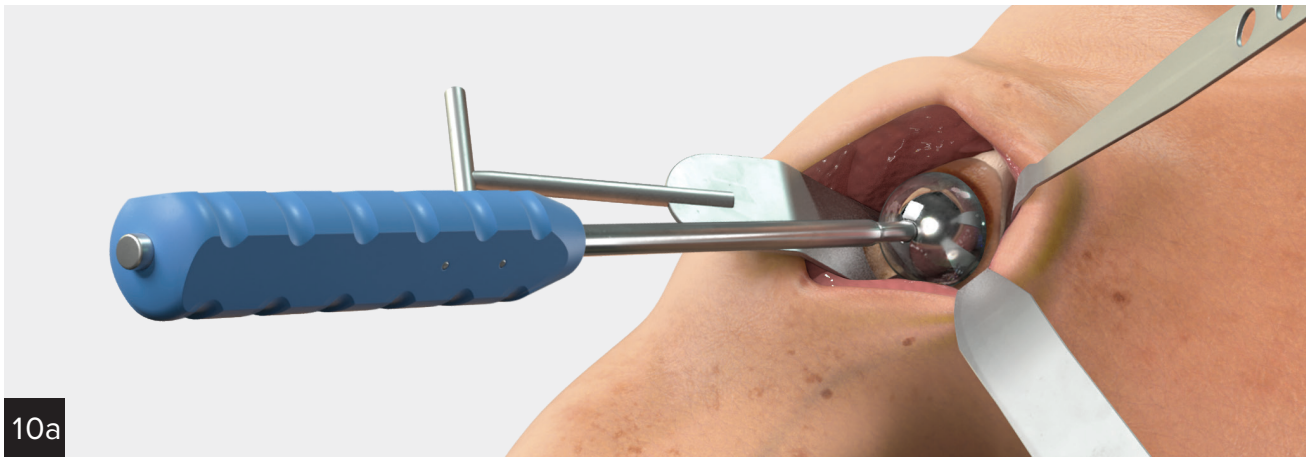

**Glenosphere Insertion:** Attach the glenosphere implant to the glenosphere inserter by threading it fully onto the handle. Introduce the glenosphere onto the baseplate taper, taking care to ensure that the taper is properly aligned. Push the glenosphere onto the baseplate until the taper is aligned/engaged. Unscrew the glenosphere inserter from the glenosphere and remove.

**Note:** For patients sensitive to cobalt alloy, titanium glenospheres are available as special order.

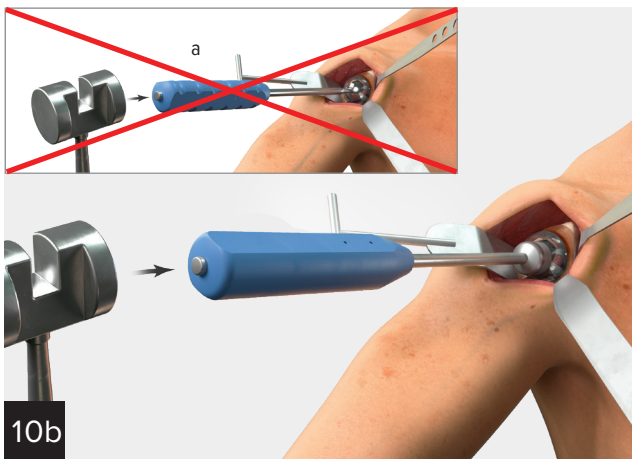

With several sharp mallet blows, impact the glenosphere onto the baseplate with the glenosphere/liner impactor (from humeral instrument tray).

**Note:** Do not impact the glenosphere onto the baseplate using the glenosphere inserter (a) as this may lead to instrument breakage.

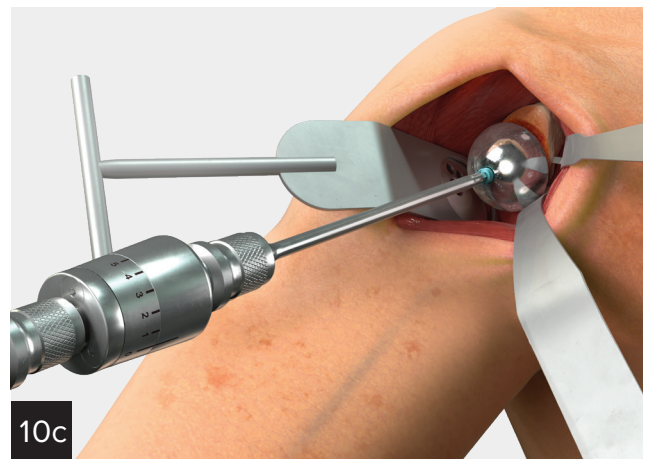

A glenosphere locking screw is packaged with the glenosphere component. Using the modular 3 mm hex driver, torque adapter, and ratcheting handle, insert the glenosphere locking screw into the glenosphere hole. Seat the screw fully, ensuring a minimum of 3 Nm of torque is applied to lock the screw.



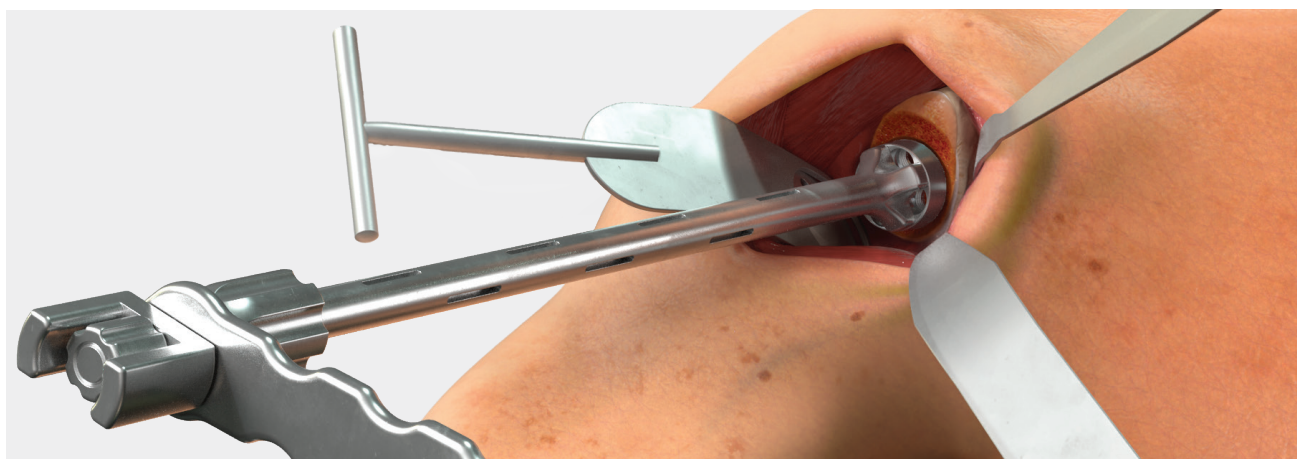

Should there be a need to remove the implant(s) in the case of a surgical revision, the following steps are recommended.

### **Revision Step 1: Glenosphere Removal**

Attach the 3 mm hex driver to the quick-connect coupling on the ratcheting handle. Ensure that the ratcheting handle is set to “Reverse” or “Locked.” Seat the tip of the hex driver in the glenosphere locking screw head and turn counterclockwise until the locking screw is backed out from the glenosphere. This screw should then be discarded.

Attach the glenosphere remover/distractor to the ratcheting handle, ensuring that the handle is set to “Forward” or “Locked.” Thread the tip of the remover/distractor into the hole within the glenosphere. Continue to advance the remover/distractor until the tip disrupts the taper connection between the baseplate and glenosphere.

### **Revision Step 2: Peripheral Screw Removal**

Reattach the 3 mm hex driver to the ratcheting handle. Insert the driver tip into the screw head. Unscrew each screw and discard.

### **Revision Step 3: Baseplate Removal**

The backside and central post/screw of the Modular Glenoid System baseplate consists of a BioSync® porous surface. To help facilitate removal, a small flexible osteotome may be used to free the backside from any bone ingrowth that may have occurred.

### **■ Central Screw Configuration**

- Place the baseplate extractor onto the baseplate. Take care to align the 4 metal nubs on the extractor face with the 4 small holes on the periphery of the baseplate face (see illustration). Thread the central rod from the baseplate extractor into the baseplate so that the faces of the baseplate and inserter/impactor are flush. Using firm counterclockwise torque, unthread the baseplate from the glenoid vault. An extractor wrench is available to aid in the process, if desired. Care should be taken during this step so as not to fracture the glenoid.

### **■ Central Post Configuration**

- Thread the baseplate extractor to the face of the baseplate, taking care to align the 4 metal nubs on the baseplate extractor face with the 4 small holes on the periphery of the baseplate face. The connection between the extractor and baseplate should be flush.
- Alternate between gentle impaction and rotation to aid in breaking the bony adhesions to the implant.
- The extractor wrench may be used to assist in freeing the baseplate backside/post from any bony ingrowth. Care should be taken during this step so as not to fracture the glenoid.
- Should the modular central post become disengaged from the baseplate during the extraction process, remove the post from the glenoid vault using the following steps (see page 18).

## Steps for Post Removal

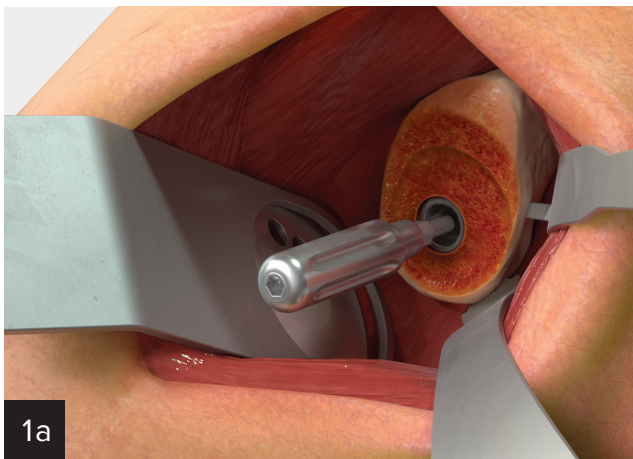

Place the central post/screw trephine adapter in the recess of the central post.

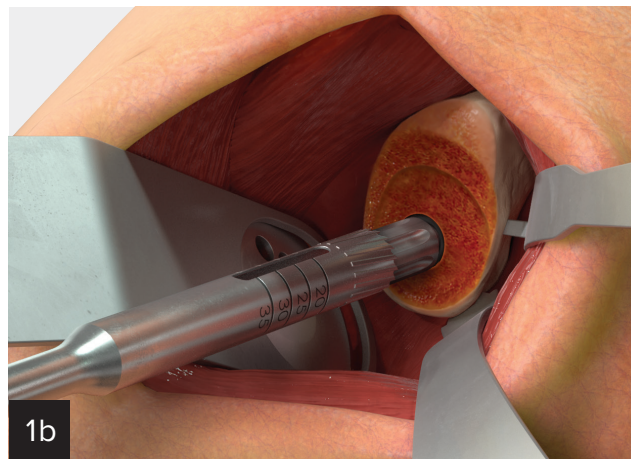

Place the central post/screw trephine into a powered drill and insert over the central post/screw trephine adapter. Rotate the trephine prior to engaging bone to avoid glenoid fracture. With the trephine, drill to a depth that corresponds to the length of the implanted central post. Verify the depth using the window and depth calibrations on the trephine.

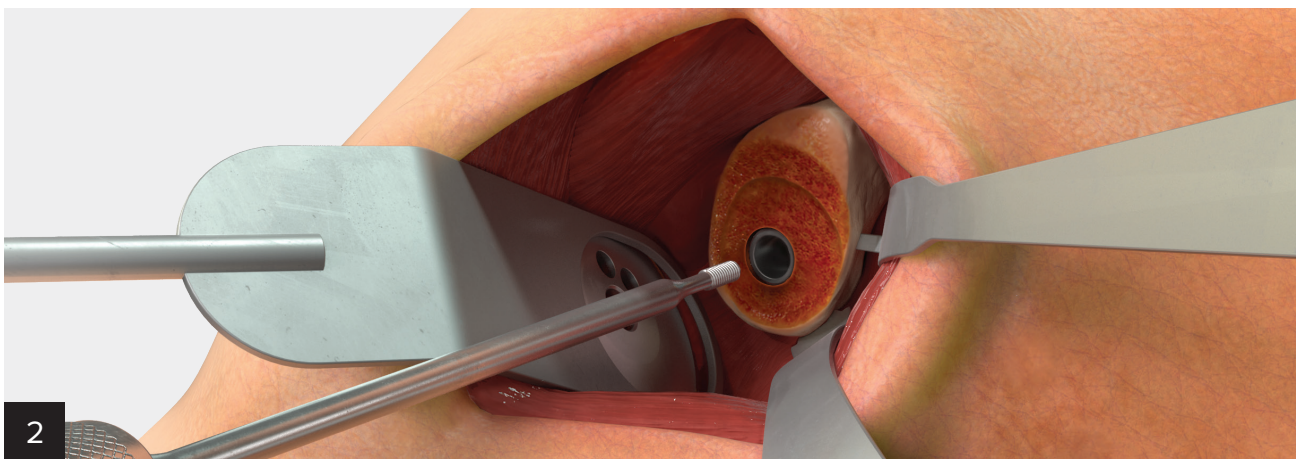

Attach the central post extractor to the ratcheting handle and thread into the central post. Twist the extractor until the threads fully seat and begin to rotate the central post within the glenoid vault. The central post/extractor may then be removed.

**Note: In cases when a central screw has been used, the 4 mm hex driver may be attached to the ratcheting handle and placed in the hex recess within the central screw to assist in component removal.**

## Univers Revers™ Combination Humeral Insert Matrix

		Glenosphere Size				
		33 mm	36 mm	39 mm	42 mm	45 mm
Suture Cup Size	33 mm	33 mm	33 mm/36 mm combo liner			
	36 mm	36 mm/33 mm step-down liner	36 mm			
	39 mm			39 mm	39 mm/42 mm combo liner	
	42 mm					42 mm

■ For use only with the Modular Glenoid System

■ For use with the Modular Glenoid System and Universal Glenoid™ System

**Note:** The 33 mm, 36 mm/33 mm and 42 mm/45 mm combo humeral inserts 33 mm and 45 mm glenospheres are only indicated for use with the Modular Glenoid System implant offering.

## Sterile Drill Bit and Measurement Card

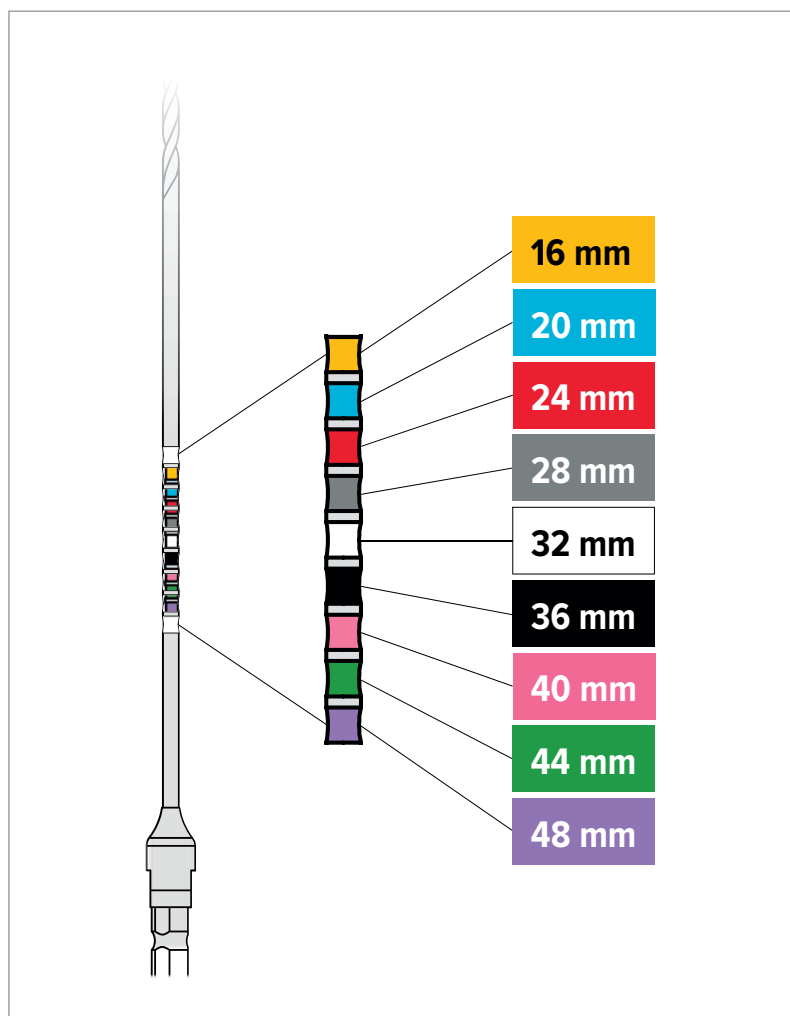

## Modular Glenoid System: Key Dimensions

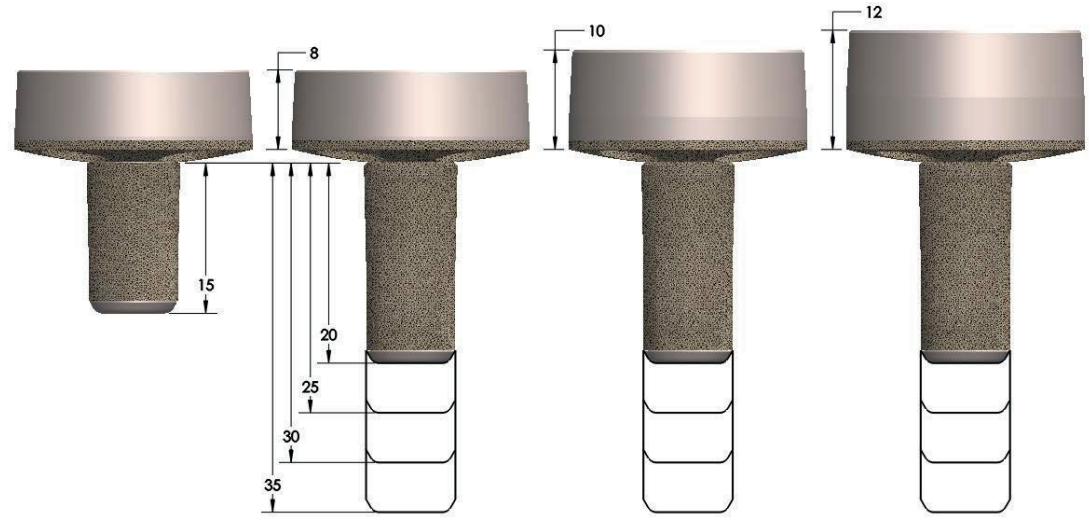
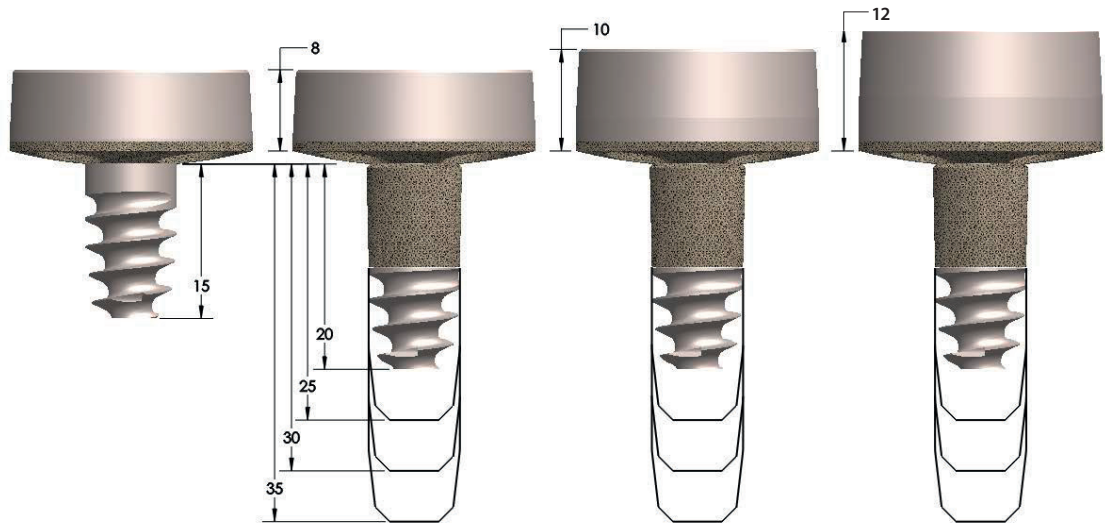
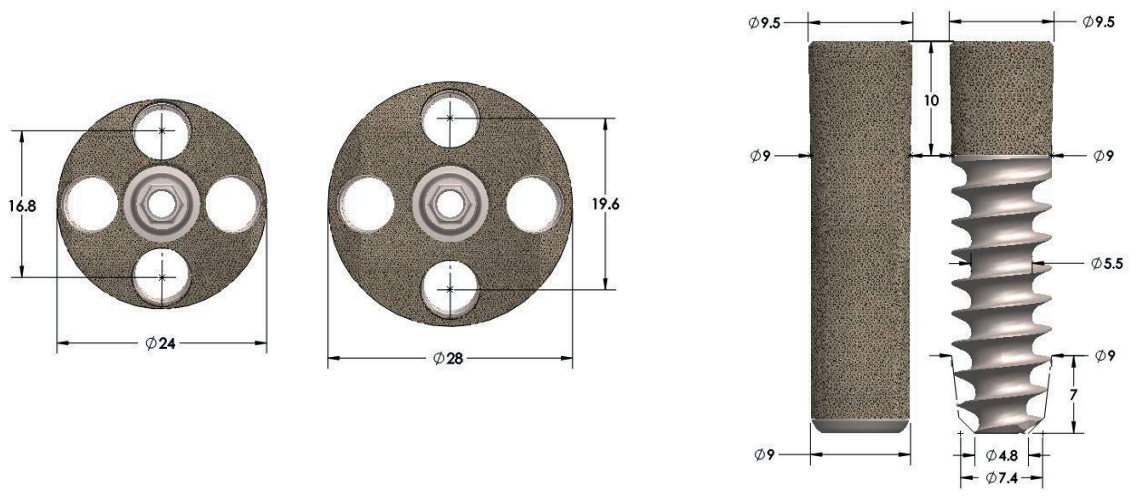

**Note: All measurements in millimeters.**



## Instrument Trays

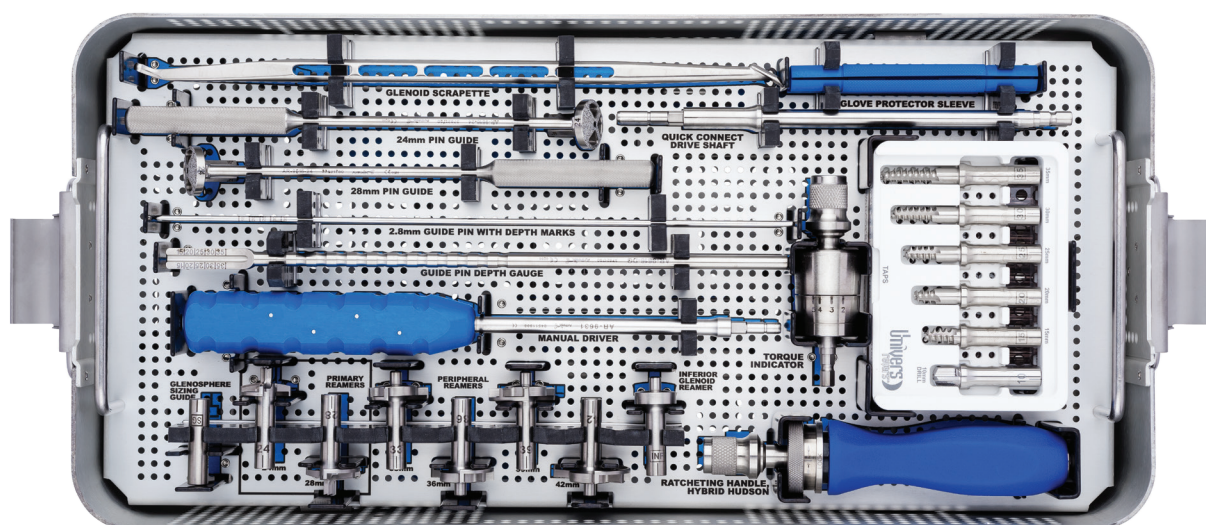

### Top Level (AR-9615C-1)

Product Description	Item Number
Glenoid scrapette	AR-9601
24 mm pin guide	AR-9616-24
28 mm pin guide	AR-9616-28
Glove protector sleeve, qty. 2	AR-9216-4
Modular reamer shaft, qty. 2	AR-9617
2.8 mm guide pin, qty. 2	AR-9616
Guide pin depth gauge	AR-9616-DG
Manual driver shaft	AR-9631
Torque indicating adapter	AR-9545-T15H
Glenosphere sizing guide	AR-9664-SG
24 mm primary glenoid reamer	AR-9618-24
28 mm primary glenoid reamer	AR-9618-28
33 mm peripheral reamer	AR-9619-33
36 mm peripheral reamer	AR-9619-36
39 mm peripheral reamer	AR-9619-39
42 mm peripheral reamer	AR-9619-42
Inferior glenoid reamer	AR-9632-INF
Racheting handle, hybrid hudson	AR-1999HH
Tap caddy	AR-9615C-TC
10 mm drill	AR-9620-10D
15 mm tap	AR-9621-15T
20 mm tap	AR-9621-20T
25 mm tap	AR-9621-25T
30 mm tap	AR-9621-30T
35 mm tap	AR-9621-35T
Drill caddy	AR-9615C-DC
15 mm drill	AR-9620-15D
20 mm drill	AR-9620-20D
25 mm drill	AR-9620-25D
30 mm drill	AR-9620-30D
35 mm drill	AR-9620-35D

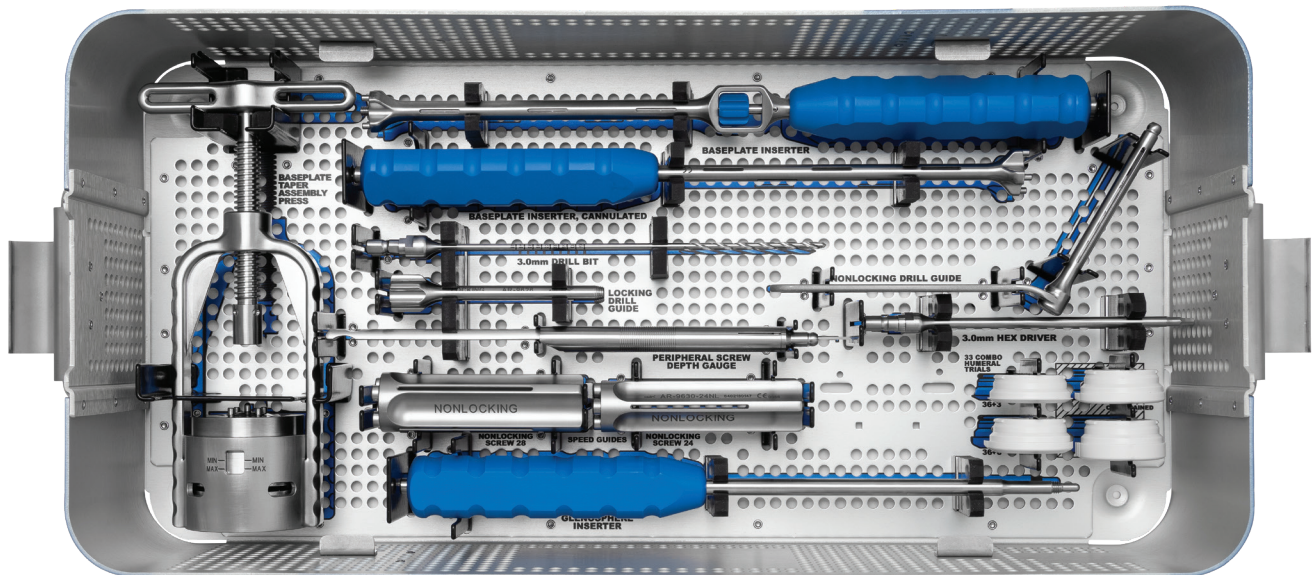

### Bottom Level (AR-9615C-1)

Product Description	Item Number
Taper assembly press	AR-9622
Baseplate inserter, threaded	AR-9623
Baseplate inserter, cannulated	AR-9623-C
3.0 mm drill, qty. 2	AR-9628
Drill guide, locking screw	AR-9626
Drill guide, nonlocking screw	AR-9627
Peripheral screw depth gauge	AR-9629
3 Mm hex driver, qty. 2	AR-9625
Speed guide for 24 mm baseplate	AR-9630-24NL
Speed guide for 28 mm baseplate	AR-9630-28NL
Baseplate inserter, cannulated	AR-9623-C
36+3 / 33 Combination humeral trial	AR-9603-3633-3
36+6 / 33 Combination humeral trial	AR-9603-3633-6
36+3 / 33 Constrained combination humeral trial	AR-9603-3633-3C
36+6 / 33 Constrained combination humeral trial	AR-9603-3633-6C
Glensphere inserter	AR-9624

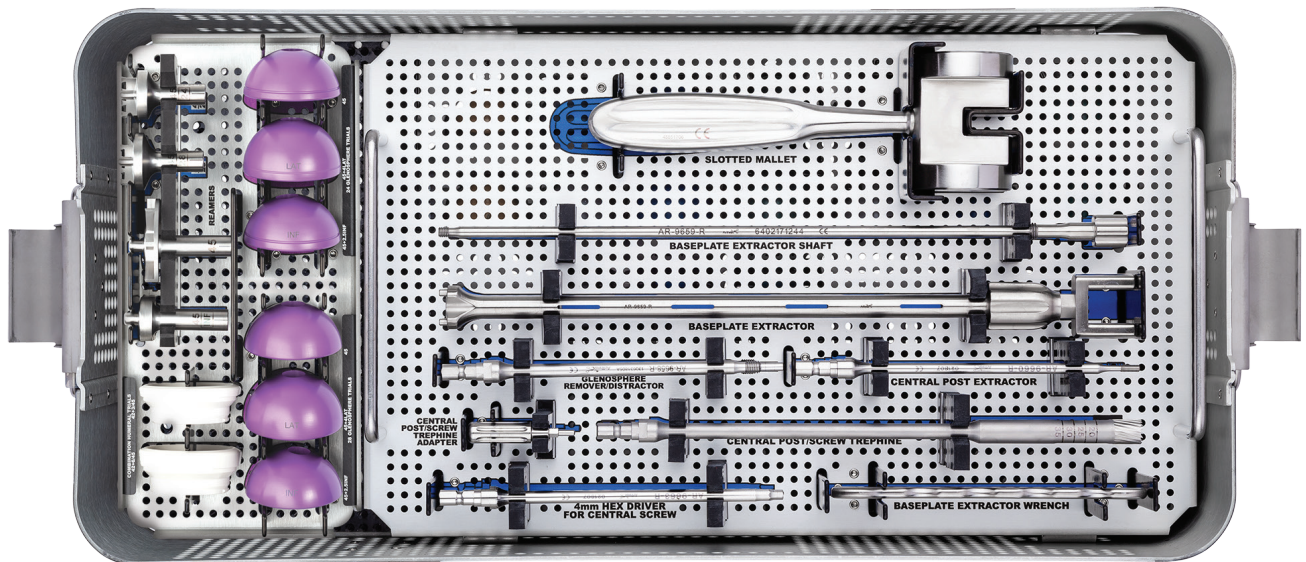

### Top Level (AR-9615C-2)

Product Description	Item Number
Slotted mallet	AR-9231-21
Baseplate extractor and extractor shaft	AR-9659-R
Glenosphere distractor	AR-9658-R
Central post extractor	AR-9660-R
Central post/screw trephine adapter	AR-9661-R
Central post/screw trephine	AR-9662-R
4 mm hex driver for central screw	AR-9663-R
Baseplate extractor wrench	AR-9659-RW
Glenosphere instruments	
45 / 24 Glenosphere trial	AR-9664-2445
45+2.5 Inf/24 glenosphere trial	AR-9664-2445-INF
45+4 Lat/24 glenosphere trial	AR-9664-2445-LAT
45 / 28 Glenosphere trial	AR-9664-2845
45+2.5 Inf/28 glenosphere trial	AR-9664-2845-INF
45+4 Lat/28 glenosphere trial	AR-9664-2845-LAT
42+3 / 45 Combination humeral trial	AR-9603-4245-3
42+6 / 45 Combination humeral trial	AR-9603-4245-6
45 mm peripheral reamer	AR-9619-45
Inferior glenoid reamer, 45	AR-9632-45INF
Over baseplate reamer, 45/24	AR-9632-2445
Over baseplate reamer, 45/28	AR-9632-2845
Ur modular glenoid case/insert 1	AR-9615C-3





### Bottom Level (AR-9615C-2)

Product Description	Item Number
33/24 Glenosphere trial	AR-9664-2433
33+4 Lat/24 Glenosphere trial	AR-9664-2433-LAT
36 / 24 Glenosphere trial	AR-9664-2436
36+2.5 Inf/24 glenosphere trial	AR-9664-2436-INF
36+4 Lat/24 glenosphere trial	AR-9664-2436-LAT
39 / 24 Glenosphere trial	AR-9664-2439
39+2.5 Inf/24 glenosphere trial	AR-9664-2439-INF
39+4 Lat/24 glenosphere trial	AR-9664-2439-LAT
42 / 24 Glenosphere trial	AR-9664-2442
42+2.5 Inf/24 glenosphere trial	AR-9664-2442-INF
42+4 Lat/24 glenosphere drill trial	AR-9664-2442-LAT
36 / 28 Glenosphere trial	AR-9664-2836
36+4 Lat/28 glenosphere trial	AR-9664-2836-LAT
39 / 28 Glenosphere trial	AR-9664-2839
39+2.5 Inf/28 glenosphere trial	AR-9664-2839-INF
39+4 Lat/28 glenosphere trial	AR-9664-2839-LAT
42/28 Glenosphere trial	AR-9664-2842
42+2.5 Inf/28 glenosphere trial	AR-9664-2842-INF
42+4 Lat/28 glenosphere trial	AR-9664-2842-LAT
Over baseplate reamer caddy	AR-9615C-RC
Over baseplate reamer, 36/24	AR-9632-2436
Over baseplate reamer, 36/28	AR-9632-2836
Over baseplate reamer, 39/24	AR-9632-2439
Over baseplate reamer, 39/28	AR-9632-2839
Over baseplate reamer, 42/24	AR-9632-2442
Over baseplate reamer, 42/28	AR-9632-2842

## Ordering Information

### Modular Glenoid System Implants

Product Description	Item Number
<b>Glenoid Baseplates</b>	
24 mm Baseplate, monoblock screw	AR-9560-24S
24 mm Baseplate, monoblock post	AR-9560-24P
24 mm Baseplate, modular	AR-9560-24
24 mm +2 Lateralized baseplate, modular	AR-9560-24-2
24 mm +4 Lateralized baseplate, modular	AR-9560-24-4
28 mm Baseplate, modular	AR-9560-28
28 mm +2 Lateralized baseplate, modular	AR-9560-28-2
28 mm +4 Lateralized baseplate, modular	AR-9560-28-4
<b>Modular Central Fixation</b>	
20 mm Modular central screw	AR-9561-20S
25 mm Modular central screw	AR-9561-25S
30 mm Modular central screw	AR-9561-30S
35 mm Modular central screw	AR-9561-35S
20 mm Modular central post	AR-9561-20P
25 mm Modular central post	AR-9561-25P
30 mm Modular central post	AR-9561-30P
35 mm Modular central post	AR-9561-35P
<b>Peripheral Bone Screws</b>	
4.5 mm × 16 mm Screw, nonlocking	AR-9562-16NL
4.5 mm × 20 mm Screw, nonlocking	AR-9562-20NL
4.5 mm × 24 mm Screw, nonlocking	AR-9562-24NL
4.5 mm × 28 mm Screw, nonlocking	AR-9562-28NL
4.5 mm × 32 mm Screw, nonlocking	AR-9562-32NL
4.5 mm × 36 mm Screw, nonlocking	AR-9562-36NL
4.5 mm × 40 mm Screw, nonlocking	AR-9562-40NL
4.5 mm × 44 mm Screw, nonlocking	AR-9562-44NL
4.5 mm × 48 mm Screw, nonlocking	AR-9562-48NL
5.5 mm × 16 mm Screw, locking	AR-9563-16
5.5 mm × 20 mm Screw, locking	AR-9563-20
5.5 mm × 24 mm Screw, locking	AR-9563-24
5.5 mm × 28 mm Screw, locking	AR-9563-28
5.5 mm × 32 mm Screw, locking	AR-9563-32
5.5 mm × 36 mm Screw, locking	AR-9563-36
5.5 mm × 40 mm Screw, locking	AR-9563-40
5.5 mm × 44 mm Screw, locking	AR-9563-44
5.5 mm × 48 mm Screw, locking	AR-9563-48
<b>Glenospheres</b>	
33 Glenosphere, 24 mm baseplate taper	AR-9564-2433
33+4 Lateralized glenosphere, 24 mm baseplate taper	AR-9564-2433-LAT
36 Glenosphere, 24 baseplate taper	AR-9564-2436
36+4 Lateralized glenosphere, 24 mm baseplate taper	AR-9564-2436-LAT

Product Description	Item Number
36+2.5 Eccentric glenosphere, 24 mm baseplate taper	AR-9564-2436-INF
39 Glenosphere, 24 mm baseplate taper	AR-9564-2439
39+4 Lateralized glenosphere, 24 mm baseplate taper	AR-9564-2439-LAT
39+2.5 Eccentric glenosphere, 24 mm baseplate taper	AR-9564-2439-INF
42 Glenosphere, 24 mm baseplate taper	AR-9564-2442
42+4 Lateralized glenosphere, 24 mm baseplate taper	AR-9564-2442-LAT
42+2.5 Eccentric glenosphere, 24 mm baseplate taper	AR-9564-2442-INF
45/24 Glenosphere	AR-9564-2445
45 +2.5 Inf/24 Glenosphere	AR-9564-2445-INF
45 +4 Lat/24 Glenosphere	AR-9564-2445-LAT
36 Glenosphere, 28 mm baseplate taper	AR-9564-2836
36+4 Lateralized glenosphere, 28 mm baseplate taper	AR-9564-2836-LAT
39 Glenosphere, 28 mm baseplate taper	AR-9564-2839
39+4 Lateralized glenosphere, 28 mm baseplate taper	AR-9564-2839-LAT
39+2.5 Eccentric glenosphere, 28 mm baseplate taper	AR-9564-2839-INF
42 Glenosphere, 28 mm baseplate taper	AR-9564-2842
42+4 Lateralized glenosphere, 28 mm baseplate taper	AR-9564-2842-LAT
42+2.5 Eccentric glenosphere, 28 mm baseplate taper	AR-9564-2842-INF
45/28 Glenosphere	AR-9564-2845
45+2.5 Inf/28 Glenosphere	AR-9564-2845-INF
45+4 Lat/28 Glenosphere	AR-9564-2845-LAT
<b>Special Order Only</b>	
42+2.5 Inf/24 Titanium glenosphere	AR-9564-T2442-INF
42/24 titanium glenosphere	AR-9564-T2442
42+4 Lat/24 titanium glenosphere	AR-9564-T2442-LAT
39+4 Lat/24 titanium glenosphere	AR-9564-T2439-LAT
39+2.5 Inf/24 titanium Glenosphere	AR-9564-T2439-INF
36/24 Titanium glenosphere	AR-9564-T2436
33+4 Lat/24 titanium glenosphere	AR-9564-T2433-LAT
36+4 Lat/24 titanium glenosphere	AR-9564-T2436-LAT
36+2.5 Inf/24 titanium glenosphere	AR-9564-T2436-INF
33/24 Titanium glenosphere	AR-9564-T2433
39/24 Titanium glenosphere	AR-9564-T2439

## Modular Glenoid System Implants

Product Description	Item Number
Miscellaneous	
Glenosphere screw, extra	AR-9565
MGS sterile pin kit	AR-9607S
3.0 MGS sterile drill bit	AR-9628S



## Indications and Contraindications

---

### Indications

The Unvers Revers Modular Glenoid System is indicated for use in a grossly rotator cuff-deficient glenohumeral joint with severe arthropathy or a previously failed joint replacement with a gross rotator cuff deficiency. The patient's joint must be anatomically and structurally suited to receive the selected implant(s), and a functional deltoid muscle is necessary to use the device. The Unvers Revers Modular Glenoid System is indicated for primary, fracture, or revision total shoulder replacement for the relief of pain and significant disability due to gross rotator cuff deficiency. The Unvers Revers Modular Glenoid System is porous coated and is intended for cementless use with the addition of screws for fixation.

The Unvers Revers Modular Glenoid System glenosphere made of titanium is indicated for patients with suspected cobalt alloy sensitivity. The wear properties of titanium and titanium alloys are inferior to that of cobalt alloy. A titanium humeral head is not recommended for patients who lack suspected material sensitivity to cobalt alloy.

### Contraindications

1. Insufficient quantity or quality of bone
2. Blood supply limitations and previous infections, which may retard healing.
3. Foreign body sensitivity. Where material sensitivity is suspected, appropriate tests should be made and sensitivity ruled out prior to implantation.
4. Any active infection or blood supply limitations.
5. Conditions that tend to limit the patient's ability or willingness to restrict activities or follow directions during the healing period.
6. Do not use for surgeries other than those indicated.

## Reference

---

1. Sites Medical Research and Development. Bone ingrowth performance of OsteoSync™ Ti. Available at: <https://www.sitesmedical.com/wp-content/uploads/The-Bone-Ingrowth-Performance-of-OsteoSync-Ti.pdf>



This description of technique is provided as an educational tool and clinical aid to assist properly licensed medical professionals in the usage of specific Arthrex products. As part of this professional usage, the medical professional must use their professional judgment in making any final determinations in product usage and technique. In doing so, the medical professional should rely on their own training and experience, and should conduct a thorough review of pertinent medical literature and the product's directions for use. Postoperative management is patient-specific and dependent on the treating professional's assessment. Individual results will vary and not all patients will experience the same postoperative activity level and/or outcomes.

View U.S. patent information at [www.arthrex.com/corporate/virtual-patent-marking](http://www.arthrex.com/corporate/virtual-patent-marking)

**arthrex.com**